



*An Online CPD Course
brought to you by
CEDengineering.ca*

Understanding Motor Nameplate Information: NEMA vs. IEC Standards

Course No: E03-009
Credit: 3 PDH

A. Bhatia



Continuing Education and Development, Inc.

P: (877) 322-5800
info@cedengineering.ca

Understanding Motor Nameplate Information - NEMA vs. IEC Standards

The motor standards can be grouped into two major categories: NEMA and IEC (and its derivatives). In North America, the National Electric Manufacturers Association (NEMA) sets motor standards, including what should go on the nameplate (NEMA Standard MG 1-10.40). In most of the rest of the world, the International Electrotechnical Commission (IEC) sets the standards or at least many countries base their standards very closely on the IEC standards. For example, Germany's VDE 0530 standard and Great Britain's BS 2613 Standard are close to IEC with minor exceptions.

The National Electrical Manufacturer's Association (NEMA) specifies that every motor nameplate must show these specific items:

- 1) Manufacturer's type
- 2) Rated volts and full load amps
- 3) Rated frequency & number of phases
- 4) Rated full load speed
- 5) Rated temperature rise or the insulation system class
- 6) Time rating
- 7) Rated horsepower
- 8) Locked rotor indicating code letter
- 9) Service Factor
- 10) Efficiency
- 11) Frame Size
- 12) Design Code

Additional information may also normally appear on the nameplates. This course will examine closely the required nameplate items starting with the NEMA standards followed by comparison between IEC and NEMA Standards.

PART-1

MOTOR NAMEPLATE INFORMATION

Industry Standards

Many of today's motor standards have been established through organizations such as the National Electrical Manufacturers' Association (NEMA), which is primarily associated with motors used in North America. The standards developed represent general industry practices and are supported by the motor manufacturers. These standards can be found in NEMA Standard Publication No# MG-1.

IEEE is another agency that has established electrical standards and recommended practices for the motor industry.

International standards exist as well, with organizations such as the International Electrotechnical Commission (IEC), the Canadian Standards Association (CSA), the Japanese Standards (JEC), the British Standards (BS) and at least one organization for each country that exists.

IEC is the organization responsible for motor standards in the European community. These standards differ from NEMA standards and can be found in IEC 34-1-16. These motors are referred to as IEC motors.

Underwriters' Laboratories (UL) is an independent testing organization that sets standards for motors and other electrical equipment. The National Fire Protection Association, which sponsors the National Electrical Code (NEC), is used by insurance inspectors and many government bodies regulating building codes. Note that neither NEMA nor IEC are testing agencies; they are organizations that establish industry standards.

NAMEPLATE DATA

A critical part of making motors interchangeable is ensuring that nameplate information is common among manufacturers. The common language of the motor nameplate enables installation and maintenance personnel to quickly understand and recognize exactly what type of motor they're dealing with during a new installation or replacement procedure. As a basic requirement of the National Electrical Code (NEC), the motor nameplate must show the following information:

- Rated voltage or voltages
- Rated full-load amps for each voltage level
- Frequency
- Phase

- Rated full-load speed
- Insulation class and rated ambient temperature
- Rated horsepower
- Time rating
- Locked-rotor code letter
- Manufacturer's name and address

Additional information will normally appear on most nameplates as well. This information might include the motor service factor, enclosure type, the frame size, connection diagrams and unique or special features. The best way to approach a basic understanding of what standardization means and to cover some of the material fundamental to standard induction motors is to examine in detail the nameplate information contained on a typical motor.

In order to fully understand the details presented on motor nameplates, we'll examine each of these items more closely and explain its importance.

#1:

MANUFACTURER'S TYPE

NEMA requires a manufacturer's type, but there is no industry standard for what this is. It is sometimes used to define 1- or 3-phase; single or multi-speed; construction, etc. The "type" definition varies from manufacturer to manufacturer.

Below are some of the "types" of motors that may be encountered:

1. **1-Phase, Shaded Pole:** Lowest starting torque, low cost, low efficiency, no capacitors. No start switch. Used on small direct-drive fans and small gear motors.
2. **1-Phase, PSC (Permanent Split Capacitor):** Similar to shaded pole applications except much higher efficiency, lower current and higher horsepower capability. Has run capacitor in circuit at all times.
3. **1-Phase, Split Phase:** Moderate to low starting torque, no capacitor and has starting switch. Used on easy start, belt-drive fans and blowers light start pump applications and gear motors.
4. **1-Phase, Capacitor-Start:** Designed in both moderate and high starting torque types with both having moderate starting current and high breakdown torque. Uses include conveyors and air compressors.

5. **3-Phase:** Generally 3-phase induction motors have a high starting torque, high power factor, high efficiency, and low current. Does not use a switch, capacitor or relay for starting. Suitable for use on larger commercial and industrial applications.
6. **AC/DC (Universal or Series wound):** Operates on AC (60 or 50 Hz) power. High speed. Speed drops rapidly as load increases. Used for drills, saws, etc., where high output and small size are desired and speed characteristic and limited life (primarily of brushes) is acceptable.
7. **Shunt Wound and Permanent Magnet DC:** High starting and breakdown torque. Provide smooth operation at low speeds. Used on constant or diminishing torque applications with Type K rectified DC power.

Motors can also be classified by their purpose:

- a. **General Purpose Motors** are designed for mechanical loads and hard to start loads, including conveyors, belt-driven equipment, machine tools, reciprocating pumps and compressors, etc. Their bearings can handle heavier radial and axial loads, and their physical construction is more heavy-duty than some other motors
- b. **Special Purpose Motors** are specifically designed for certain applications. For example, HVAC motors are primarily designed for fans, centrifugal pumps, small tools, office equipment, and other light to medium duty applications. Other types of definite duty motors include wash down, hazardous location, farm duty, pump duty, universal AC/DC, vacuum, etc.

Some manufactures simply add the model, date and serial number here to aid in identification. You will also sometime notice other logos of additional agencies shown on the nameplate, including the UL recognition label, the 'CE' mark for the European Community and the Canadian Standards Association logo.

#2:

RATED VOLTS

The rated voltage is the voltage at which the motor is designed to operate and yield optimal performance. Nameplate-defined parameters for the motor such as power factor, efficiency, torque, and current are at rated voltage and frequency. Application at other than nameplate voltage will likely produce different performance.

Since line voltage is apt to vary over a period of time due to power system load conditions, the motor must be designed to cope with some voltage variations. Standard induction motors

are designed to tolerate voltage variations plus or minus 10%. Thus, a motor with a nameplate voltage rating of 230 could be expected to give satisfactory but not necessarily ideal performance when supplied with power ranging from a low value of 207 to a high extreme of 253 volts.

Manufacturers often put a wide variety of voltages on the nameplate. For example, a motor wound for 230 and 460 V (230/460 V) but operable on 208 V. In this case the nameplate would read 208-230/460 and will have degraded performance at 208 V.

#3:

FULL LOAD AMPS (FLA)

When the full-load torque and horsepower is reached, the corresponding amperage is known as the full-load amperage (FLA). This value is determined by laboratory tests; the value is usually rounded up slightly and recorded as the nameplate value. Rounding up allows for manufacturing variations that can occur and some normal voltage variations that might increase the full-load amps of the motor. The nameplate FLA is used to select the correct wire size, motor starter, and overload protection devices necessary to serve and protect the motor.

Rated full load current is often abbreviated as ‘FLA’ on the nameplate. Unbalanced phases, under-voltage conditions, or both, cause current to deviate from nameplate amps.

#4:

RATED FREQUENCY

This indicates the frequency for which the motor is designed in hertz (cycles per second). 60 Hertz power is utilized throughout the United States and Canada, as well as a few other countries. Motors are designed to tolerate a frequency variance of plus or minus 5%, and a motor should be able to handle both voltage and frequency variations at the same time.

The motors designed to operate varying speeds using variable frequency drive (VFD); the frequency range is normally given.

#5:

NUMBER OF PHASES

In most industrial and commercial installations, the power systems, and consequently the induction motors, will either be single phase or three phase. The cost effectiveness and

efficiency of the three phase induction motor makes it the natural choice for all requirements where three phase power is available.

Single phase motors may be used on fractional horsepower requirements (less than one horsepower) and in applications where three phase power is not available (usually through a maximum horsepower rating of 10 HP).

#6:

FULL LOAD RPM

The rated full load speed, or rpm (revolutions per minute) of a motor is the speed at which the motor will operate under full torque conditions when applied voltage and frequency are held constant at the rated values.

An induction motor's speed is always less than synchronous speed and it drops off as load increases. For example, for 1800 rpm synchronous speed, an induction motor might have a full-load speed of 1750 rpm. On standard induction motors, the full load speed, or actual speed, will normally be between 96 and 99% of synchronous speed. This is also known as slip.

Multi-speed shaded pole and PSC motors show maximum speed first, followed by total number of speeds (i.e., 3000/3-Spd). Multi-speed split phase and capacitor-start motors have maximum speed shown first, followed by second speed (i.e., 1725/1140). RPM rating for a gear motor represents output shaft speed.

Note: "High" efficiency motors have usually higher speed ratings than comparable sized standard efficiency motors. This higher operating speed can actually increase power consumption in centrifugal loads (e.g., pumps and fans). For centrifugal loads, power varies as the cube of speed. Thus, a 1% increase in speed will result in a 3% increase in power ($1.01^3 = 1.03$).

#7:

SYNCHRONOUS SPEED

Synchronous speed is the theoretical speed of a motor based on the rotating magnetic field. This is determined by the following equation:

$$S = (120 \times F)/P$$

Where:

- S = speed in RPM

- F = frequency in hertz
- P = Number of poles in motor

Or, if you know the number of poles in your motor, you can determine the speed by the following table:

No. of Poles	Synchronous Speed	Actual Speed
2	3600	3450
4	1800	1725
6	1200	1140
8	900	850

#8:

RATED TEMPERATURE RISE OR INSULATION CLASS

One of the most critical items relating to the life of motors is the maximum temperature that occurs at the hottest point within the unit and the length of time that the high temperature is allowed to exist. The maximum allowable safe operating temperature occurring at the hottest spot within a motor is determined by:

1. The temperature of the air surrounding the motor. This is the ambient temperature. Motors are rated using a 40°C ambient (104°F).
2. The heat created within the motor due to its operation at a fully loaded condition. This is the temperature rise.
3. The thermal capability of all the insulating materials used within the motor. For simplicity, these materials have been broken into classes A, B, F and H.

This standard 20,000 hour life temperature class is based on ambient plus the heat created within the motor during operation.

Please keep in mind that motors are designed to withstand some very high temperatures. As an example, Class B is rated at 130°C, which is 266°F, or 54 degrees above the boiling point of water. Motors have been designed to withstand this type of heat.

Insulating materials prevent metal to metal contact or interaction of phase to phase shorts. This is also known as dielectric strength. It limits the effects of voltage variations. Insulation System Classes are as follows:

Class	20,000 Hour Life Temperature
A	105°C
B	130°C
F	155°C
H	180°C

Insulation classes perform better in an ascending alphabetical order. For example, class F insulation has a longer nominal life at a given operating temperature than class A, or for a given life it can survive higher temperatures.

#9:

MAXIMUM AMBIENT TEMPERATURE

The nameplate lists the maximum ambient temperature at which the motor can operate and still be within the tolerance of the insulation class at the maximum temperature rise. It is often abbreviated as "AMB" on the nameplate.

10:

ALTITUDE

This indicates the maximum height above sea level at which the motor will remain within its design temperature rise, meeting all other nameplate data. If the motor operates below this altitude, it will run cooler. *At higher altitudes, the motor would tend to run hotter because the thinner air cannot remove the heat so effectively, and the motor may have to be derated.* Not every nameplate has an altitude rating.

11:

TIME RATING

Time rating or duty specifies the length of time the motor can operate at its rated load safely and indicates whether the motor is rated for continuous duty. This is shown as "CONT" on the nameplate.

Standard motors are rated for continuous duty (24/7) at their rated load and maximum ambient temperature. Specialized motors can be designed for “short-time” requirements where intermittent duty is all that is needed.

These motors can carry a short-time rating from 5 minutes to 60 minutes. The NEMA definition for short-time motors is as follows: “All short-time ratings are based upon corresponding short-time load tests, which shall commence only when the windings and other parts of the motor are within 5°C of the ambient temperature at the time of the test.” By using short-time ratings, it's possible to reduce the size, weight, and cost of the motor required for certain applications. For example, you may choose to install an induction motor with a 15-minute rating to power a pre-operation oil pump used to pre-lube a gas turbine unit because it would be unusual for this type of motor to be operated for more than 15 minutes at a time.

Other examples of intermittent duty applications include crane, hose, valve actuator etc. *The intermittent duty rating is typically expressed in minutes.*

12:

RATED HORSEPOWER

This represents the rated horsepower output when the motor is loaded to rated torque at rated speed. The standardized NEMA table of motor horsepower ratings runs from 1 hp to 450 hp. When application horsepower requirements fall between two standardized values, the larger size is usually chosen. This adds a margin of safety that will reduce the motor's operating temperature rise and extend the operating life of the motor.

AC motors used in North America are generally rated in horsepower. Equipment manufacturing in Europe is generally rated in kilowatts (KW). Horsepower can be converted to kilowatts using the following formula:

$$KW = .746 \times HP$$

Kilowatts can be converted to horsepower using this formula:

$$HP = 1.341 \times KW$$

The relationship between horsepower and torque should also be noted here. Torque is the turning or twisting force supplied by a drive to the load. Units of measure are inch pounds or foot pounds. Torque and horsepower are related to each other by the following formula:

$$\text{Horsepower (hp)} = [\text{Motor Speed} \times \text{Torque (lb-ft)}] \div 5,250$$

13:

TORQUE

Torque is the turning or twisting force supplied by a drive to the load, measured in inch pounds or foot-pounds. Torque and horsepower are related as shown:

$$\text{HP} = (\text{Torque} \times \text{Speed}) / \text{Constant}$$

- If Torque is given in ft-lbs, the constant is 5,252
- If Torque is given in in-lbs the constant is 63,025

14:

LOCKED ROTOR kVA CODE

When AC motors are started with full voltage applied, they draw line currents substantially greater than their full load running current rating. The magnitude of the so-called inrush current is a function of motor horsepower and the design characteristics of the motor. The value of this high current can be important on some installations because it can cause a voltage dip that might affect other equipment.

In order to define the inrush characteristics and present them in a simplified form, a series of code letters group motors depending on the range of inrush in terms of kilovolt amperes. The code letter defines low and high voltage inrush values on dual voltage motors. The electrician installing the motor uses this information to properly size the starter for the motor. The following is a listing of the code letter designations:

Code	kVA/HP	Approx. Mid-Range Value
A	0.00-3.14	1.6
B	3.15-3.54	3.3
C	3.55-3.99	3.8
D	4.00-4.49	4.3
E	4.50-4.99	4.7
F	5.00-5.59	5.3

G	5.60-6.29	5.9
H	6.30-7.09	6.7
J	7.10-7.99	7.5
K	8.00-8.99	8.5
L	9.00-9.99	9.5
M	10.00-11.99	10.6
N	11.20-12.49	11.8
P	12.50-13.99	13.2
R	14.00-15.99	15.0

The chart provides the locked-rotor code letter that defines an inrush current a motor requires when starting it. The chart defines the locked-rotor kVA on a per-HP basis and indicates that inrush current per HP increases per letter. Replacing a motor with a higher locked rotor code may require additional upstream electrical equipment to handle the higher inrush currents.

Using this chart and the job voltage, you can calculate ‘the across the line starting inrush’ by using the following:

200 Volts LRA = Code letter value x HP x 2.9

230 Volts LRA = Code letter value x HP x 2.5

460 Volts LRA = Code letter value x HP x 1.25

This is used by the installer to determine the proper branch circuit protection rating.

15:

POWER FACTOR (PF)

Power factor on the nameplate is sometimes abbreviated as PF or P.F. Power factor is the ratio of active power (W) to apparent power (VA), expressed as a percentage. The power factor is also equal to the cosine (“Cos”) of the angle formed by the lag between the current with respect to the voltage.

For induction motors, the power factor varies with load. Power factor is minimum at no load and increases as additional load is applied to the motor. Power factor usually reaches a peak at or near full load on the motor.

It can vary from 0 to 1 and is for the full load condition. It is desirable to have high power factors close to unity (100%). The power factor can be improved by adding capacitors.

In NEMA motors the power factor is abbreviated as “PF” and for IEC motors the power factor is tagged as “Cos”.

16:

SERVICE FACTOR (SF)

Motor Service Factor (SF) is the percentage of overloading the motor can handle for short periods when operating normally within the correct voltage tolerances. This is practical as it gives you some 'fudge' in estimating horsepower needs and actual running horsepower requirements. It also allows for cooler winding temperatures at rated load, protects against intermittent heat rises, and helps to offset low or unbalanced line voltages. For example, the standard SF for open drip-proof (ODP) motors is 1.15. This means that a 10-hp motor with a 1.15 SF could provide 11.5 hp when required for short-term use. Some fractional horsepower motors have higher service factors, such as 1.25, 1.35, and even 1.50.

NEMA defines service factor as a multiplier, when applied to the rated horsepower, indicates a permissible horsepower loading, which may be carried under the conditions specified for the service factor at rated voltage and frequency. This service factor can be used for the following:

1. To accommodate inaccuracy in predicting intermittent system horsepower needs.
2. To lengthen insulation life by lowering the winding temperature at rated load.
3. To handle intermittent or occasional overloads.
4. To allow occasionally for ambient above 40°C.
5. To compensate for low or unbalanced supply voltages.

NEMA does add some cautions, however, when discussing the service factor:

1. Operation at service factor load for extended periods will usually reduce the motor speed, life and efficiency.
2. Motors may not provide adequate starting and pull-out torques, and incorrect starter/overload sizing is possible. This in turn affects the overall life span of the motor.
3. Do not rely on the service factor capability to carry the load on a continuous basis.
4. The service factor was established for operation at rated voltage, frequency, ambient and sea level conditions.

Most motors have a duty factor of 1.15 for open motors and 1.0 for totally closed motors. Traditionally, totally enclosed fan cooled (TEFC) motors had an SF of 1.0, but most

manufacturers now offer TEFC motors with service factors of 1.15, the same as on ODP motors. Most hazardous location motors are made with an SF of 1.0, but some specialized units are available for Class I applications with a service factor of 1.15.

The service factor is required to appear on the nameplate only if it is higher than 1.0.

17:

FULL LOAD NOMINAL EFFICIENCY

Efficiency is defined as the ratio of the power output divided by the power input. Machine losses are in the form of heat, and include stator winding loss, rotor loss, core loss (hysteresis and eddy current), friction and windage, and stray load loss.

NEMA standard MG1-12.54.2 provides instructions for establishing the value of efficiency. The standard states that the nominal efficiency shown on the nameplate shall not be greater than the average efficiency of a large population of motors of the same design. Also, the full load efficiency, when operating at rated voltage and frequency, will not be less than the minimum value associated with the nominal value.

Care should be taken in comparing efficiencies from one motor manufacturer to another. It is difficult to compare efficiencies based on published, quoted or test data, due to the fact that there is no single standard method which is used throughout the industry. The most common referred to standards are IEEE 112 (U.S.), IEC (International), JEC-27 (Japanese), BS-269 (British) and ANSI C50.20 (same as IEEE 112). IEEE 112 is used more than any of the others in the United States, while allowing for a variety of test methods to be used. The preferred procedure is IEEE method B, where the motor is operated at full load, and the power is directly measured.

Generally, larger motors will be more efficient than smaller motors. Today's premium efficiency 3-phase motors have efficiencies ranging from 86.5% at 1 hp to 95.8% at 300 hp. The efficiency value that appears on the nameplate is the "nominal full-load efficiency" as determined using a very accurate dynamometer and a procedure described by IEEE Standard 112, Method B. The nominal value is what the average would be if a substantial number of identical motors were tested and the averages of the batch were determined. Some motors might have a higher value and others might be lower, but the average of all units tested is shown as the nominal nameplate value. Thus, essentially the rating Nom Eff. 92.1 means this is an average efficiency of this motor model, but actual efficiency may vary.

The efficiency is reduced by any form of heat, including friction, stator winding loss, rotor loss, core loss (hysteresis and eddy current), etc. The actual motor efficiency is guaranteed

to be within a band of this nominal efficiency by the manufacturer. The efficiency band varies from manufacturer to manufacturer. The maximum allowable "band" is 20% set by NEMA. This is a large range; therefore pay close attention to the manufacturer's actual minimum guarantee!

18:

FRAME SIZE (optional)

Most motor dimensions are standardized and categorized by a frame size number and letter designation. This system was developed by NEMA and specific frame sizes have been assigned to standard motor ratings based on enclosure, horsepower and speed. The number describes the mounting dimensions, including foot hole mounting pattern, shaft diameter, shaft height, etc. However, it does not define overall length and height, conduit box extension length, etc.

The current standardized frames for integral horsepower induction motors ranges from 143T to 445T. These standards cover most motors in the range of one through two hundred horsepower.

The numbers used to designate frame sizes have specific meanings based on the physical size of the motor. The first two digits are related to the motor shaft height and the remaining digit or digits relate to the length of the motor. As a rule of thumb, you can calculate the shaft height on horizontal motors in inches, ("D" dimension), by dividing the first two digits of the frame size by four. Please note that this works on all foot-mounted NEMA frame motors in 143T through 445T frames.

The third digit of the frame size is related to the length of the motor but there is no rule of thumb that can be easily applied.

It is important to note that when standard foot-mounted motors have frame sizes that differ only in the third digit, the shaft diameters, shaft lengths, and distance from the end of the shaft to the bolt holes in the feet on the shaft end of the motor will be the same.

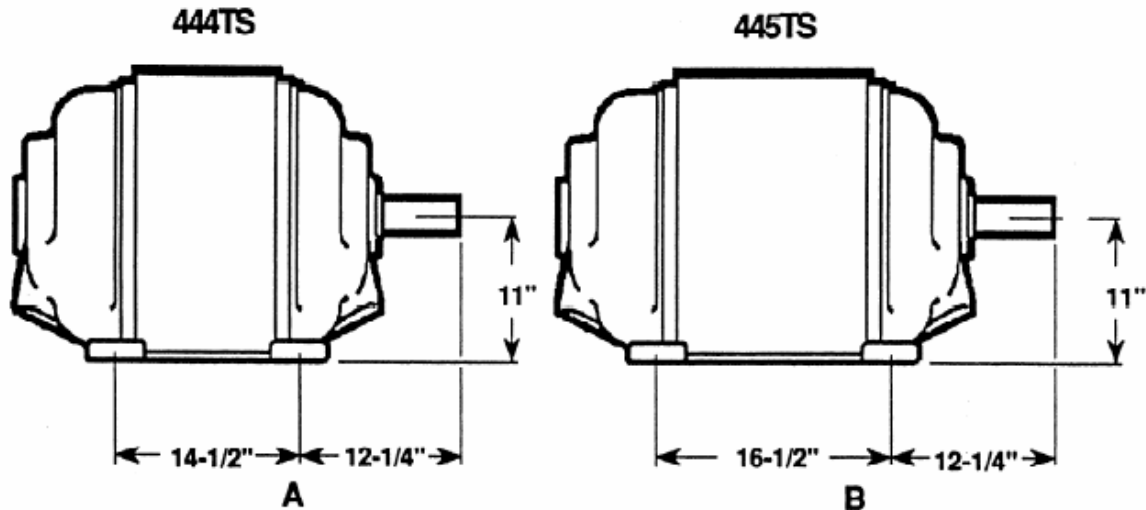

The length difference in the examples above occurs between the feet as shown by dimensions A and B. The suffix T indicates that the motor frame assignment conforms to the current, or so called “T” frame “Nu-Rate” standards which were adopted in 1964.

Note that the frame size refers to mounting only and has no direct bearing on the motor body diameter. In general, as a frame number becomes higher, so does the physical size of the motor and the horsepower. There are many motors of the same horsepower built in different frames.

When working with metric motors (IEC type), the concept is the same as noted above with one exception: the shaft height above the base is now noted in millimeters rather than inches. The frame size is the shaft height in millimeters. (The details are further described later in the course).

Some common frame examples include:

Number	Definition
C	NEMA C face mounting (specify with or without rigid base)
D	NEMA D flange mounting (specify with or without rigid base)
H	Indicates a frame with rigid base having an F dimension larger than that of the same frame without the suffix H. For example, combinations of 56H base motors have mounting holes for NEMA 56 and NEMA 143-5T and a standard NEMA 56 shaft.

Number	Definition
J	NEMA C face, threaded shaft pump motor
JM	Close-coupled pump motor with specific dimensions and bearings
JP	Closed-coupled pump motor with specific dimensions and bearings
M	6 3/4" flange (oil burner)
N	7 1/4" flange (oil burner)
T, TS	Integral horsepower NEMA standard shaft dimensions if no additional letters follow the "T" or "TS."
TS	Motor with NEMA standard "short shaft" for belt driven loads
Y	Non-NEMA standard mount; a drawing is required to be sure of dimensions. Can indicate a special base, face or flange.
Z	Non-NEMA standard shaft; a drawing is required to be sure of dimensions.

For further standard designations refer to NEMA MG 1- 11.01.

19:

NEMA DESIGN LETTER

Changes in motor windings and rotor design will alter the performance characteristics of induction motors. To obtain uniformity in application, NEMA has designated specific designs of general purpose motors having specified locked rotor torque, breakdown torque, slip, starting current, or other values. There are standard definitions for designs A, B, C and D. The letter designation describes the torque and current characteristics of the motor.

NEMA Design A motors has normal starting torques, but high starting currents. This is useful for applications with brief heavy overloads. Injection molding machines are a good application for this type of motor.

NEMA Design B motors have normal starting torque, with low starting current. These are the most widely used design, and have locked rotor torques adequate for starting a wide variety of industrial machines and locked rotor starting currents acceptable to most power systems. Some Design B applications would include machine tools, fans and blowers, compressors, chippers, and centrifugal pumps. These are the most common type of motors.

NEMA Design C motors have high starting torque (approximately 225%) and low starting current. These motors have high locked rotor torque and relatively high full load slip. They are especially suited for starting heavy loads such as reciprocating compressors, stokers, crushers and pulverizers, as well as positive displacement pumps due to their high locked rotor torques and high full load slip.

NEMA Design D motors have high starting torque and low starting current, but with high slip. At no load the motor operates with little slip. When peak load is applied, the motor slip increases appreciably, allowing the unit to absorb the energy. This reduces power peaks supplied by the electrical system, resulting in a more uniform power requirement. These motors may be used on applications like a low speed punch press with a heavy flywheel, or hoisting applications.

20:

ENCLOSURE TYPE

The enclosure of the motor must protect the windings, bearings, and other mechanical parts from moisture, chemicals, mechanical damage and abrasion from grit. NEMA standards MG1-1.25 through 1.27 define more than 20 types of enclosures under the categories of open machines, totally enclosed machines, and machines with encapsulated or sealed windings. The most common types of enclosures are:

Open Drip Proof (ODP): Allows air to circulate through the windings for cooling, but prevent drops of liquid from falling into motor within a 15 degree angle from vertical. Typically used for indoor applications in relatively clean, dry locations.

Totally Enclosed Fan Cooled (TEFC): Prevents the free exchange of air between the inside and outside of the frame, but does not make the frame completely airtight. A fan is attached to the shaft and pushes air over the frame during its operation to help in the cooling process. The ribbed frame is designed to increase the surface area for cooling purposes. The TEFC style enclosure is the most versatile of all. It is used on pumps, fans, compressors, general industrial belt drive and direct connected equipment.

Totally Enclosed Non-Ventilated (TENV): Similar to a TEFC, but has no cooling fan and relies on convection for cooling. No vent openings, tightly enclosed to prevent the free exchange of air, but not airtight. These are suitable for uses which are exposed to dirt or dampness, but not very moist or hazardous (explosive) locations.

Totally Enclosed Air Over (TEAO): Dust-tight fan and blower duty motors designed for shaft mounted fans or belt driven fans. The motor must be mounted within the airflow of the fan.

Totally Enclosed Wash down (TEWD): Designed to withstand high pressure wash-downs or other high humidity or wet environments. Available on TEAO, TEFC and TENV enclosures

Totally enclosed, hostile and severe environment motors: Designed for use in extremely moist or chemical environments, but not for hazardous locations.

Explosion-proof enclosures (EXPL): The explosion proof motor is a totally enclosed machine and is designed to withstand an explosion of specified gas or vapor inside the motor casing and prevent the ignition outside the motor by sparks, flashing or explosion. These motors are designed for specific hazardous purposes, such as atmospheres containing gases or hazardous dusts. For safe operation, the maximum motor operating temperature must be below the ignition temperature of surrounding gases or vapors. Explosion proof motors are designed, manufactured and tested under the rigid requirements of the Underwriters Laboratories.

Hazardous Location (HAZ): Hazardous location motor applications are classified by the type of hazardous environment present, the characteristics of the specific material creating the hazard, the probability of exposure to the environment, and the maximum temperature level that is considered safe for the substance creating the hazard.

The format used to define this information is a class, group, division and temperature code structure as defined by the National Electric Code (NFPA-70). The following hazardous locations are defined:

1) **CLASS I**

- Group A: Acetylene
- Group B: Butadiene, ethylene oxide, hydrogen, propylene oxide, manufactured gases containing more than 30% hydrogen by volume.
- Group C: Acetaldehyde, cyclopropane, diethyl ether, ethylene.

- Group D: Acetone, acrylonitrile, ammonia, benzene, butane, ethanol, ethylene dichloride, gasoline, hexane, isoprene, methane (natural gas), methanol, naphtha, propane, propylene, styrene, toluene, vinyl acetate, vinyl chloride, xylene.

2) **CLASS II**

- Group E: Aluminum, magnesium, and other metal dusts with similar characteristics.
- Group F: Carbon black, coke or coal dust.
- Group G: Flour, starch or grain dust.

3) **CLASS III**

- Easily ignitable fibers, such as rayon, cotton, sisal, hemp, cocoa fiber, oakum, excelsior and other materials of similar nature.

The NEMA enclosure description is similar to the IEC Index of Protection (IP) code. The NEMA designations are more descriptive and general, whereas the IEC IP codes are more precise and narrowly defined by a 2-digit code, with the first digit defining how well protected the motor is from solid objects and the second digit describing how well protected the motor is from moisture. For example, a NEMA "Open Drip Proof (ODP)" motor corresponds to an IP22 and a NEMA "Totally Enclosed" motor corresponds to an IP54, a NEMA "Weather-Proof" motor to an IP45, and a NEMA "Wash-Down" motor to an IP55.

21:

THERMAL PROTECTION

Thermal protection describes the motors over temperature protection, if so equipped. Thermal protection can include the following:

Auto (Automatic Reset): Contains temperature-sensing device that disconnects one leg of its power source if temperature becomes excessive due to failure-to-start or overload. After motor cools, thermal protector automatically restores power. Should not be used where unexpected re-starting would be hazardous

Imp (Impedance): Motor is designed so that it will not burn out in less than 15 days under locked rotor (stalled) conditions, in accordance with UL standard No. 519.

Man (Manual Reset): Contains a temperature-sensing device that disconnects one leg of its power source if temperature becomes excessive due to failure-to-start or overload. After motor cools, an external button must be pushed to restore power to the motor. Turn off power prior to attempting to reset motor protector. Preferred where unexpected re-starting would be hazardous, as on saws, conveyors, compressors, etc

None: Motor contains no temperature-sensing device to protect motor from excessive temperature due to failure-to-start or overload. Motor should be protected by other means in accordance with the NEC and local code requirements.

T-St (Thermostat): A temperature-sensing device installed inside the motor with separate leads brought out for connection into motor starter pilot circuit. Under failure-to-start or overload conditions, thermostat contacts will open. Thermostat contacts will reclose automatically when motor cools.

Other data

A typical nameplate also includes the motor's brand name, and it includes a "Serial No." or other identifying number unique to that motor, that would let the manufacturer trace the motor back through manufacturing. The nameplate also includes the manufacturer's name, and its principal city and state and "Made in U.S.A." if U.S.-made.

Bearings (optional)

Though NEMA does not require it, many manufacturers supply nameplate data on bearings. Many special bearings are applied in motors for reasons such as high speed, high temperature, high thrust, or low noise. It pays to understand your motors' bearing requirements. The main types are:

Sleeve: Preferred where low noise level and low cost is important, as on fan and blower motors.

Ball: Where higher load capacity and/or less frequent lubrication is desired. Ball bearings are pre-lubricated and protected to keep out contaminants.

Ball & Sleeve: Ball bearing on shaft end, sleeve on terminal box end.

Roller: For rolling-element bearings, the most common is the "AFBMA Number." That is the number that identifies the bearing by standards of the Anti-Friction Bearing Manufacturers Association.

Shaft Type (optional)

This describes the output shaft. The general shaft types include:

Flat: Usually found on motors with up to 1/2" diameter shaft. A length of flat is governed by NEMA standards. Balance of shaft is round.

Key: Primarily used on motors with 5/8" and larger shaft diameter. Key size is determined by NEMA standards.

Round: Used on small C-frame shaded pole motors. Full length of shaft is round.

Thd (Threaded): Used on uni-directional motors for special applications such as driving impeller of jet pumps. Threaded in opposite direction to shaft rotation so driven device tightens on shaft.

Others are available for specific applications.

Mounting (optional)

This describes the method of mounting the motor. Unless specified otherwise, motors can be mounted in any position or any angle. However, unless a drip cover is used for shaft-up or shaft-down applications, drip-proof motors must be mounted in the horizontal or sidewall position to meet the enclosure definition. Mount motors securely to the mounting base of equipment or to a rigid, flat surface, preferably metallic.

The basic types of mount include:

Rigid base: Motor is provided with base which is either welded, bolted or cast on main frame and allows motor to be rigidly mounted on equipment.

Resilient base: A base which is isolated from motor shell with vibration-absorbing material, such as rubber rings. A conductor is imbedded in the ring to complete the circuit for grounding purposes.

NEMA C face mount: Is a machined face with a pilot on the shaft end which allows direct mounting with a pump or other direct coupled equipment. Bolts pass through mounted part to threaded hole in the motor face. Commonly used on jet pumps, oil burners and gear reducers. The mounting dimensions are based on industry (NEMA) standards.

NEMA D flange mount: Is a machined flange with rabbet for mountings. Bolts pass through motor flange to a threaded hole in the mounted part.

Type M or N mount: Has special flange for direct attachment to fuel atomizing pump on an oil burner. In recent years, this type of mounting has become widely used on auger drives in poultry feeders.

Extended through-bolt: Have bolts protruding from the front or rear of the motor by which the driven load is mounted. This is usually used in applications involving small direct drive fans or blowers. Positioning of studs or bolts do not relate to an industry standard, but will

usually be common for a given motor diameter. When replacing motor, on-center distance of studs or bolts should be checked.

Holes: Threaded holes are machined into motor and are usually located on shaft end. Hole positions do not relate to an industry standard, but motors intended for specific applications will usually have the same hole patterns. When replacing a motor, the on-center dimensions of holes should be checked.

Yoke: Tabs are welded to bottom of motor shell for bolting to a fan column or bracket. Used on fan-duty motors only.

Hub: A mounting ring on shaft end of motor. Designed to fit specific applications, such as carbonator pumps and pedestal sump pumps.

Power Factor Correction (Max Corr KVAR) (Optional)

If given, this is the maximum power factor correcting capacitor size to be used. Value is typically given in kVARs. Using higher values than specified could result in higher voltages which could damage the motor or other components.

Special markings

Many motor nameplates have special markings to reflect third-party certification or recognition. Some common markings are:

CSA (Canadian Standards Association): CSA indicates that the manufacturing system and the motor components meet the standards of, and are continually reviewed by the Canadian Standards Association.

UL (Underwriters Laboratories): UL indicates that the manufacturing system and the motor components meet the standards of, and are continually reviewed by, Underwriters Laboratories.

ASD (Adjustable Speed Drive): A growing area of nameplate marking relates to capabilities of a motor when used on an adjustable speed drive. Many standard motors are applied to adjustable speed drives (ASDs) using general rules of thumb, without the motor manufacturer even knowing of the application. However, given the proper information about the ASD and application, a motor manufacturer can design a motor, or properly apply an existing design, and stamp the approved parameters on the nameplate. This stamping is always required on UL-listed explosion-proof motors.

PART – 2

NEMA V/s IEC standards

The International Electrotechnical Commission (IEC) is the international counterpart to the North American- National Electrical Manufacturers Association (NEMA) standards.

The NEMA and IEC standards use different terms, but they are essentially analogous in ratings and, for most common applications, are largely interchangeable. In brief NEMA standards tend to be more conservative while IEC standards tend to be more precise, specific and more categorized.

Now that we understand the NEMA motor terminology, here's a primer on the most common designations of IEC and how they relate to NEMA standards.

Frame relationships

Both IEC and NEMA motors use a letter code to specify the physical frame dimensions, but the codes are different.

The frame designation for IEC motors is composed of a two-part letter/number code. The letter portion of the code specifies the physical frame dimensions, while the number portion of the code specifies the general frame size.

The letters can get especially tricky, for example, a "K" code for an IEC motor is equivalent to a NEMA "H", whereas an IEC "H" is equivalent to a NEMA "D".

The numeric portion of the code (indicating frame size) is less confusing and there is less overlap; for instance an IEC "56" is for sub-fractional motors whereas a NEMA "56 is from ¼ - 1.5 HP motors).

The IEC also defines a motor's mounting position and connecting flange type by a code. A couple of the more common mounting position codes include B3 for foot mounted and B5 for footless. Three different flange types are defined: FF, FT and FI flanges. The FF flange has through bolt holes, and is available for frame sizes from 56 to 280. The FT flange has threaded bolt holes and is also available for frame sizes from 56 to 280.

Note that all the IEC dimensions are in metric units.

Enclosure designations

Like NEMA, IEC has designations indicating the protection provided by a motor's enclosure. However, where NEMA designations are in words, such as Open Drip Proof or Totally Enclosed Fan Cooled, the IEC uses a two-digit "Index of Protection" code to describe how

well the enclosure protects the motor from the environment. The first digit indicates how well protected the motor is against the entry of solid objects, the second digit refers to water entry. The two digit number is followed by letters “IP”.

Here's what the first digit means:

0 - No protection

1 - Protection against objects larger than 50mm (about 2 in.) in diameter, like hands

2 - Protection against objects larger than 12mm (about 1/2 in.) in diameter, like fingers

4 - Protection against objects larger than 1mm (about 0.04 in.) in diameter, like small tools and wires

5 - Complete protection, including dust-tightness.

The second digit signifies protection against water entry. Here are those ratings:

0 - No protection

1 - Protected from water falling straight down

2 - Protected from water falling as much as 15 deg from vertical

3 - Protected from spraying water as much as 60 deg from the vertical

4 - Protected from splashing water coming from any direction

5 - Protected against jets of water from all directions

6 - Protected from heavy seas

7 - Protected against the effects of immersion to depths of between 0.15 and 1.0 m

8 - Protected against the effects of prolonged immersion at depth

By way of general comparison, the NEMA designations are more descriptive and general, whereas the IEC IP codes are more precise and narrowly defined. For most industrial application, an IP 22 relates to open drip-proof motors, IP44 or IP54 to totally enclosed, IP45 to weatherproof, and IP55 to wash-down duty motors. For explosion proof motors, the hazardous atmospheres defined by national electrical code parallel those of the IEC "flame-proof" motors.

Cooling designations

Again, IEC uses a letter and number IC code to designate how a motor is cooled. There is an individual code for just about every type of cooling method, from small fan cooled motors

to large liquid cooled motors. The code can get quite complex; up to a four-letter and four-digit code.

A few of the more common "short codes" are shown below:

IC 01 - The first digit indicates that the air can flow freely in and out of the motor. The second digit indicates that the airflow is caused by an integral fan, or "self-induced". This corresponds to a standard NEMA open fan-cooled motor because of the internal-fan action.

IC 40 - The first digit means the frame surface (external enclosure) is cooled (i.e. no internal flow). The second digit indicates that cooling by convection only with without a fan action. This corresponds to a NEMA totally enclosed, non-vented (TENV) motor.

IC 41 - The first digit again indicates frame-surface cooling, but the second indicates that airflow over the motor is caused by an integral fan. This corresponds to a NEMA Totally Enclosed Fan-Cooled (TEFC) motor.

IC 48 - The first digit indicates that the external frame/enclosure surface is cooled (i.e., no internal flow). But the second says that the motor is in the air stream of the driven fan or blower. This corresponds to a NEMA Totally Enclosed, Air-Over motor (TEAO). This relates to uses where the motor is in air stream of the fan or blower it drives, and is thus cooled by fan action.

Thus for most practical purposes, IC 01 relates to a NEMA open design, IC 40 Totally Enclosed Non-Ventilated (TENV), IC 41 to Totally Enclosed Fan Cooled (TEFC), and IC 48 to Totally Enclosed Over (TEAO).

Duty Cycles

The NEMA motors refer to duty cycle in one of two or three terms: continuous, intermittent or special duty (typically expressed in minutes). IEC breaks it into eight ratings:

S1 - Continuous duty: The motor works at a constant load for enough time to reach temperature equilibrium.

S2 - Short-time duty: The motor works at a constant load, but not long enough to reach temperature equilibrium, and the rest periods are long enough for the motor to reach ambient temperature.

S3 - Intermittent periodic duty: Sequential, identical run and rest cycles with constant load. Temperature equilibrium is never reached. Starting current has little effect on temperature rise.

S4 - Intermittent periodic duty with starting: Sequential, identical start, run and rest cycles with constant load. Temperature equilibrium is not reached, but starting current affects temperature rise.

S5 - Intermittent periodic duty with electric braking: Sequential, identical cycles of starting, running at constant load and running with no load. No rest periods.

S6 - Continuous operation with intermittent load: Sequential, identical cycles of running with constant load and running with no load. No rest periods.

S7 - Continuous operation with electric braking: Sequential identical cycles of starting, running at constant load and electric braking. No rest periods.

S8 - Continuous operation with periodic changes in load and speed: Sequential, identical duty cycles run at constant load and given speed, and then run at other constant loads and speeds. No rest periods.

Design Types

The IEC design rating code describes a motor's speed vs. torque characteristics. The IEC Design codes nearly mirror NEMA Design Types, but with different letters. For example, the most common industrial motor is an IEC Design N motor, which is very similar to a NEMA Design B motor; the most common type of motor for industrial applications. By the same token, the characteristics of IEC Design H are nearly identical to those of NEMA Design C. There is no specific IEC equivalent to NEMA Design D.

Logically the suffix with IEC has a meaning. Say comparing torques of IEC Design N (*think of it as "normal" torque*) motors in general mirror those of NEMA Design B motors. The torque of IEC Design H (*think of it as "high" torque*) is nearly identical to those of NEMA Design C.

Insulation designations

IEC and NEMA use the same classification system for winding insulation. It is based on the highest temperature the material can withstand continuously without degrading or reducing motor life. The table below compares temperature rises (add 45°C for total acceptable temperature) allowed under IEC and NEMA standards.

IEC V/s NEMA Temperature Rise, degrees C			
Insulation Class	IEC (1.0 Service Factor)	NEMA (1.0 Service Factor)	NEMA (1.15 service Factor)
A	60	60	70
E	75	*	*
B	80	80	90
F	100	105	115
H	125	125	-

*Note that NEMA has no Class E.

Most industrial-duty motors use Class B or Class F insulation, depending on the application. IEC and NEMA 1.00 service factor ratings are nearly identical; NEMA 1.15 ratings are higher.

Kilowatts & horsepower

This is the rated shaft power output at the rated voltage, current and frequency. IEC uses kilowatts (kW) and NEMA uses horsepower (hp). The conversion between the two is $1\text{hp} = 745.7\text{ W} = 0.7457\text{kW}$

Like NEMA, IEC assigns comparable power ratings to standard frame sizes.

IEC and NEMA kW/hp comparisons flows smoothly in smaller ratings, but in larger sizes they can vary enough to cause concern in some design applications. An example is IEC 115S/NEMA364T areas for 4-pole motors. Here, NEMA calls for 75 hp in the frame size in which IEC calls for 50 hp. Dropping to a NEMA 326T frame provides the 50 hp needed if the dimensioning differences can be tolerated. If you need the 364T dimensions, be sure not to damage the drive train or load with the higher-power motor.

Rated Voltage (Volts)

IEC standard 34-1 requires that motors be able to provide their rated output at their rated efficiency for a voltage range of 95% to 105% of the rated voltage.

Efficiency

The efficiency for IEC motors is usually given at full load or at 75% load. Also, an efficiency rating (EFF1, EFF2, and EFF3) may appear on the motor.

Service Factor (not used for IEC motors)

IEC motors do not have a "Service Factor" rating definition. Instead, the temperature rise, ambient temperature and altitude ratings are defined via the kW output rating. If an increased service factor is required, use the next size larger motor.

That's a short guideline in nameplate terminology and IEC/NEMA comparisons. IEC rating's in general follows a more logical, systematic, and descriptive path than those of NEMA.

Summary

As the markets continue to become more global, the common language of the motor nameplate will enable the electrical engineers/technicians to quickly understand and recognize exactly what type of motor they're dealing with during a new selection, installation or replacement procedure.

While NEMA standards are for the North America markets, the rest of the world follows the IEC standards. Selecting and replacing motors become a lot easier when you can quickly recognize the key items that describe a motor's size, speed, voltage, physical dimensions, and performance characteristics. All of this information and more is usually available on the motor's nameplate. Verifying conformance of NEMA to IEC or other industry standards would enable you to apply motors correctly anywhere on the project site.

In general, the IEC standards are much more precise than the NEMA standard, defining endurance and make/ break rating for each motor size. NEMA standards are not as precise and take on a more conservative approach.